

THREE POINT FREE LINK HITCH ATTACHMENT OF IMPLEMENTS TO AGRICULTURAL WHEELED TRACTORS—SAE J715b

SAE Standard

Report of Tractor Technical Committee approved April 1959 and last revised June 1964. Conforms to report of FEL Advisory Engineering Committee, Chicago, Illinois.

Scope—This specification sets forth requirements for the attachment of three point hitch implements or equipment to the rear of agricultural wheeled tractors by means of a three point free link in association with a power lift.

In order to assure proper performance of certain implements, standard dimensions for mast height, mast pitch adjustment and implement leveling adjustment are included. Location of link attachment points is not restricted and is, therefore, left to the discretion of the tractor designer.

If draft links are used for trailing power take-off implements, the manufacturer shall make provision for locking the draft links in a fixed position and provide a drawbar hitch point in conformance with power take-off standards.

Dimensions comprising the standard specifications are divided into three categories:

Category	Drawbar hp, Max*
1	Up to 45
2	40-100
3	80 and over

* Based on SAE J708, paragraph 2.5.

Definition of Terms

Linkage—The combination of one upper link and two lower links, each articulated to the tractor and the implement at opposite ends in order to connect the implement to the tractor.

UPPER LINK; LOWER LINK—Elements in the linkage.

Hitch Point—The articulated connection between a link and the implement. For geometrical analysis, the hitch point is established

as the center of the articulated connection between a link and the implement.

Link Point—The articulated connection between a link and the tractor. For geometrical analysis, the link point is established as the center of the articulated connection between a link and the tractor.

Upper Hitch Point—The articulated connection between the upper link and the implement.

Upper Link Point—The articulated connection between the upper link and the tractor.

Lower Hitch Point—The articulated connection between a lower link and the implement.

Lower Link Point—The articulated connection between a lower link and the tractor.

Upper Hitch Pin—The pin that connects the upper link to the implement.

Upper Link Pin—The pin that connects the upper link to the tractor.

Lower Hitch Stud or Pin—The stud or pin, attached to the implement, on which a lower link is secured.

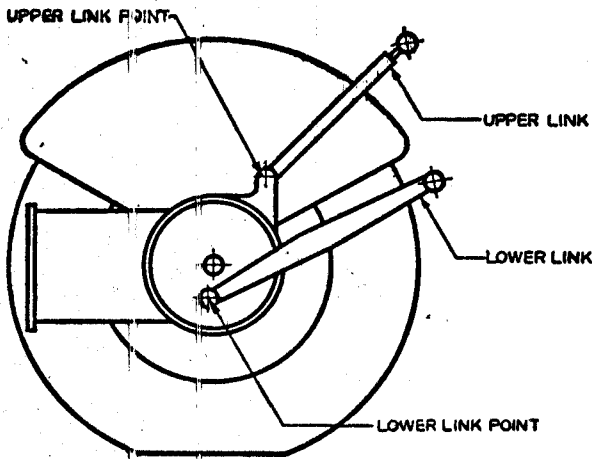

FIG. 1—TRACTOR LINKAGE

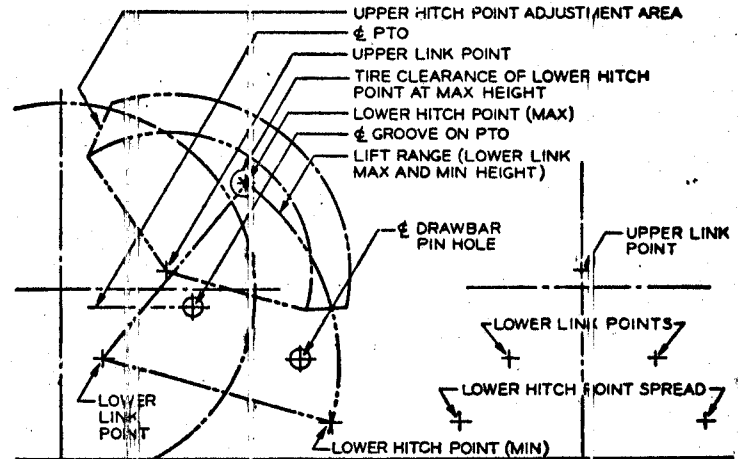
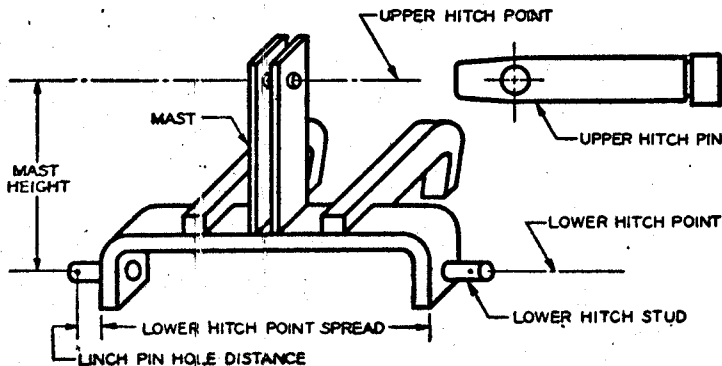

FIG. 2—DIMENSIONS ASSOCIATED WITH TRACTOR

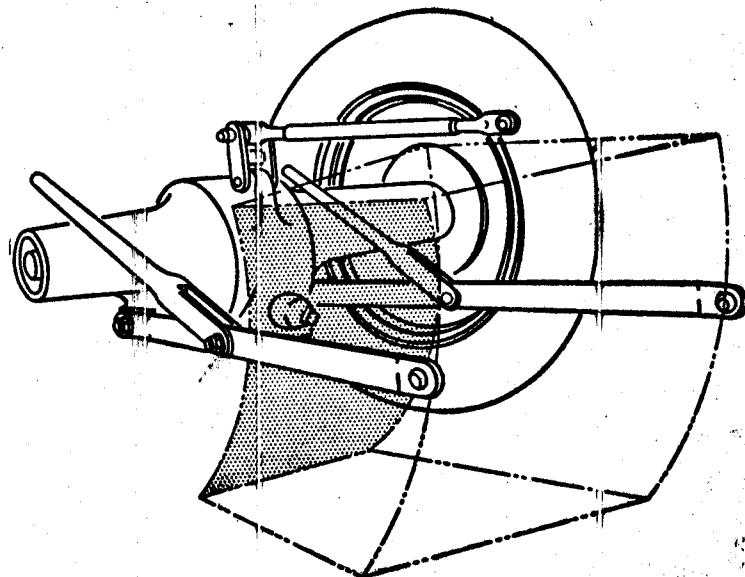

FIG. 3—LOWER HITCH POINT TRACTOR CLEARANCE

Linchpin—The retaining pin used in the hitch pins or studs.

Mast—The member that provides attachment of the upper link to the implement.

Mast Height—The perpendicular distance between the upper hitch point and common axis of the lower hitch points.

Mast Adjustment—The usable range of movement of the mast in a

vertical plane. It is measured as the maximum and minimum heights of the lower hitch points above the ground between which a mast of standard height can be adjusted to any inclination between the vertical and 5 deg from the vertical, towards the rear.

Leveling Adjustment—The adjustment of the lower links so that one lower hitch point may be moved vertically with respect to the

TABLE 1—DIMENSIONS ASSOCIATED WITH IMPLEMENT

	CATEGORY 1				CATEGORY 2				CATEGORY 3			
	in.		mm		in.		mm		in.		mm	
	Min	Max	Min	Max	Min	Max	Min	Max	Min	Max	Min	Max
Upper Hitch Point												
Width inside	1.75	—	44.5	—	2.06	—	52.3	—	2.06	—	52.3	—
Width outside	—	2.73	—	69.3	—	3.38	—	85.9	—	3.75	—	95.3
Clearance radius for upper link ^a	2.25	—	57.2	—	2.25	—	57.2	—	2.25	—	57.2	—
Hitch pin hole diameter	0.76	0.77	19.3	19.56	1.01	1.02	25.65	25.91	1.26	1.27	32.0	32.26
Lower Hitch Point												
Stud diameter	0.86	0.87	21.84	22.10	1.11	1.12	28.19	28.45	1.43	1.44	36.32	36.58
Linch pin hole distance	1.53	—	38.86	—	1.91	—	48.52	—	1.91	—	48.52	—
Linch pin hole diameter	0.46	0.48	11.68	12.19	0.46	0.48	11.68	12.19	0.46	0.48	11.68	12.19
Lower hitch point spread	26.81	26.94	681.0	684.3	32.38	32.50	822.5	825.5	37.94	38.06	963.7	966.7
Clearance radius for lower link ^a	2.50	—	63.5	—	2.88	—	73.2	—	3.25	—	82.6	—
Implement encroachment in front of lower hitch point, if implement extends laterally behind tire	—	0.5	—	12.7	—	0.5	—	12.7	—	0.5	—	12.7
Implement Mast Height^{b,c}	—	18	—	457	—	18	—	457	—	22	—	559

^a Some tractors with quick attachable connectors require 5.50 in. (140 mm) space for clearance above the upper hitch point and below the lower hitch points.

^b The mast height is not necessarily a mechanical dimension of the implement itself. It is a figure used in design, and, if properly used for design of both implement and tractor, a well performing interchangeable implement and tractor combination will be achieved. This standard makes it possible to produce tractors and implements that will give good performance in any combination; therefore, consideration to hitch geometry is essential. This makes it desirable to establish a standard mast height and a standard mast adjustment within a working range, because these items influence the position of hitch points that are common to both the implement and the tractor.

^c Mast height is one of the essential factors in establishing the virtual hitch point of the free link system, draft signal for the draft responsive system, loads on the linkage and hitch points,

changes in implement pitch corresponding to changes in working depth, implement pitch when the implement is in transport position, clearance of the implement with the tractor, especially in transport position and clearance of the hitch links with the implement or with the tractor, especially in the transport position.

When an implement mast height is made different than standard to accomplish some specific performance feature, care should be exercised to insure that the desired performance is secured with tractor likely to operate the implement.

^c Some Category 2 tractors are designed to accommodate a 22 in. (559 mm) mast height for optimum performance. In the design of implements for use on these tractors care should be taken to investigate the need for providing a 22 in. (559 mm) mast height. Tractors that are designed only for use with 22 in. (559 mm) mast height must be properly identified.

TABLE 2—DIMENSIONS ASSOCIATED WITH TRACTOR

	CATEGORY 1				CATEGORY 2				CATEGORY 3			
	in.		mm		in.		mm		in.		mm	
	Min	Max	Min	Max	Min	Max	Min	Max	Min	Max	Min	Max
Upper Link												
Width at hitch point	—	1.73	—	43.9	—	2.01	—	51.1	—	2.01	—	51.1
Radius at hitch point	—	2.00	—	50.8	—	2.00	—	50.8	—	2.00	—	50.8
Hitch pin hole diameter	0.76	0.77	19.3	19.56	1.01	1.02	25.65	25.91	1.26	1.27	32.0	32.26
Side sway at hitch point	—	(See note ^b)	—	—	—	(See note ^b)	—	—	—	(See note ^b)	—	—
Upper Hitch Pin												
Diameter	0.74	0.75	18.8	19.05	0.99	1.00	25.15	25.40	1.24	1.25	31.50	31.75
Distance from head to centerline of linch pin hole	3.00	—	76.2	—	3.64	—	92.5	—	4.00	—	101.6	—
Linch pin hole diameter	0.46	0.48	11.68	12.19	0.46	0.48	11.68	12.19	0.46	0.48	11.68	12.19
Lower Link												
Width at hitch point	1.37	1.38	34.80	35.05	1.37	1.76	34.8	44.7	1.74	1.76	44.2	44.7
Radius at hitch point	—	1.75	—	44.5	—	2.62	—	66.5	—	3.00	—	76.2
Stud hole diameter	0.88	0.89	22.35	22.61	1.13	1.14	28.70	28.96	1.45	1.46	36.83	37.08
Lower hitch point tire clearance with largest R-1 type tire offered	3	—	76.2	—	3	—	76.2	—	3	—	76.2	—
Lower hitch point tractor clearance	18	—	457	—	18	—	457	—	18	—	457	—
Side sway at hitch point each side of center position with draft links horizontal ^a	4	—	102	—	5	—	127	—	5	—	127	—
Horizontal distance from end of power take-off shaft to lower hitch points with draft links horizontal	18	21	457	533	18	21	457	533	20	21	508	533
		(See note ^a)				(See note ^a)						
Lift Range, Power Range, Adjustments, and Tractor Lift Force Capacity												
Lift range:												
Maximum height for lowest position	—	8	—	203	—	8	—	203	—	8	—	203
Minimum height for highest position	32	—	813	—	36	—	914	—	40	—	1016	—
Power range	22	—	559	—	24	—	610	—	26	—	660	—
Leveling adjustment:												
Higher	4.0	—	102	—	4.5	—	114	—	5.0	—	127	—
Lower	4.0	—	102	—	4.5	—	114	—	5.0	—	127	—
Mast adjustment:												
Minimum height for highest position	20	—	508	—	24	—	610	—	26	—	660	—
Maximum height for lowest position	—	10	—	254	—	10	—	254	—	10	—	254
Tractor lift force capacity												

A minimum lift force of 40 lb (18.14 kg) for each maximum drawbar horsepower of the tractor, shall be available at the distance 24 in. (610 mm) to the rear of the lower hitch points and throughout the power range, using 10% of the minimum hydraulic relief valve pressure setting.

^a Means should be provided to lock the draft links in a rigid lateral position for power take-off work, for other operations where side sway cannot be tolerated and when the hitch is raised to the transport position. No maximum dimensions for sideways are specified; this must be limited in each individual application so that hitch or implement components will not come in contact

with the tractor tires.

^b Side sway of the upper link must be compatible with that provided at the lower links plus necessary additional allowance for lateral leveling adjustment.

^c For future design, 20–21 in. (508–533 mm) preferred.

other lower hitch point to provide an inclination of the implement.

Lower Hitch Point Spread—The distance between lower hitch points measured at the base of the lower hitch stud, or the distance between the innermost restraining means provided on the implement.

Linchpin Hole Distance—The distance between the linchpin hole centerline and the lower link stud base.

Lift Linkage—The connecting linkage that transmits force to the lower links for raising and lowering.

Lift Range—The range of movement of the lower hitch points utilizing the extent of manual adjustment provided in the lift linkage in conjunction with the power range, expressed as the maximum and minimum possible heights of the lower hitch points above ground level, the lower hitch point axis being maintained horizontal to the

ground.

Power Range—The total vertical movement of the lower hitch point excluding any adjustment in the linkage or lift linkage.

Lower Hitch Point Tire Clearance—Clearance expressed as radial dimension from the lower hitch point to the outside diameter of the tire with the implement in raised position and all side sway removed from the links.

Lower Hitch Point Tractor Clearance—The horizontal dimension between the rearmost parts of the tractor in the area between the two draft links and the horizontal line through the two lower hitch points throughout the range of vertical movement of the hitch points. See Fig. 4. The power take-off master shield may be removed, if necessary to meet this dimension.